

Heat Exchanger Systems

VARITUBE[®] Tubular Heat Exchangers

VARITHERM[®] Plate Heat Exchangers

 Innovative Engineering –
Quality in Line.



GEA TDS ...

is established internationally as a specialist for technically and economically optimised process technology, and a competent partner for heat exchanger systems for the treatment of milk products, food and juice.

Heat exchangers are at the heart of all process plants for heating, cooling, pasteurising or UHT heating. GEA TDS use plate and tubular heat exchangers, depending on the plant configuration. Whether you are planning to process smooth products or products containing particles with low or high viscosities – our experienced and competent team of experts provides solutions which are exactly tailored to your needs.

VARITUBE® Tubular Heat Exchangers

The VARITUBE® tubular heat exchanger is specifically designed for the thermal treatment of low- to high-viscosity products as well as products containing particles, pulp and fibres.

The VARITUBE® system is mainly used in heating, cooling, and aseptic systems.

Application-oriented technology

According to the required production capacity and the physical properties of the product, the most appropriate design can be selected from numerous versions of our VARITUBE® heat exchangers. Depending on the area of application, customised designs can also be developed and installed. Our VARITUBE® range is used for many products that need to be heated, cooled, pasteurised, and UHT treated.



VARITUBE®

Tubular Heat Exchangers

Technical concept

The VARITUBE® tubular heat exchanger is a straight-tube heat exchanger with one or more inner tubes situated in a shell. The inner tubes can either be plain or corrugated. Corrugation and the optimised product/media volume ratio increase the thermal efficiency of our heat exchangers.

Their modular design allows for easy installation and easy extensions or future modifications.

VARITUBE® modules are TÜV-approved and manufactured from 1.4404/1.4571 (AISI 316 L/Ti) material. A sanitary sealing system and product flow paths without “dead zones” ensure highest production reliability and product quality. Easy maintenance and inspection and low service costs are further features of our heat exchangers.

VARITUBE® S – Singletube

for indirect heat treatment of products containing pieces. Product recovery is possible using pigging technology. A tubular heat exchanger in which the product flows in one straight inner tube, while a heat-carrying medium flows around it in an external shell. The inner tube is mounted in a fixed or floating manner to compensate for the different thermal expansions caused by high temperature differences between shell and inner tube.

VARITUBE® M – Multitube

with indirect heat exchange, which is also suitable for products containing particles of approx. 18 mm diameter. The product flows in several straight inner tubes while a heat-carrying medium flows around it in a shell. The inner tube is mounted in a fixed or floating manner to compensate for the different thermal expansions caused by high temperature differences between shell and inner tube.

Further characteristics of VARITUBE® S and M

- Modular design with 2 or 4 modules
- Removable inner bundle
- Plain or corrugated inner tubes
- Lengths of 3 or 6 m
- EHEDG approved and certified

VARITUBE® P – used for the direct product/product heat recovery of smooth, fibre-contained and viscous products. In this tubular heat exchanger the product is guided through several straight inner tubes surrounded by the same product, which flows in a counter-current direction in the shell. The inner tubes are mounted in a floating manner and can be removed as a complete bundle for inspecting the product flow path.

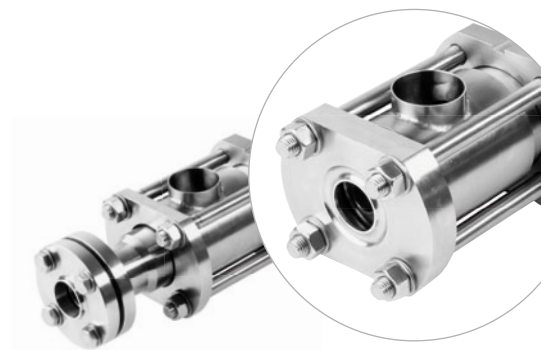

VARITUBE® P



VARITUBE® S und M
Plain and corrugated inner tubes



VARITUBE® Tubular Heat Exchangers

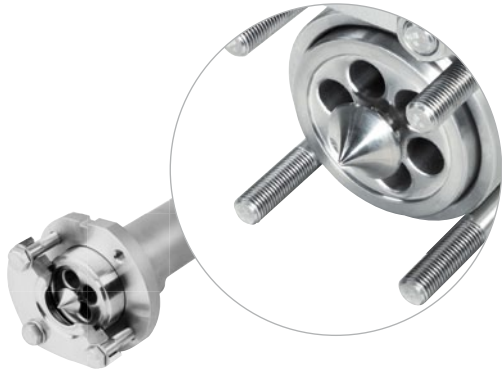

VARITUBE® SK

VARITUBE® SK – is a specially designed flow device that keeps the heat exchanger free from deposits – it processes products containing fibres with a length of up to 30 mm, and to enable an even distribution of the product to all tubes.

This heat exchanger is available in an M version (VARITUBE® M-SK) and in a P version (VARITUBE® P-SK).

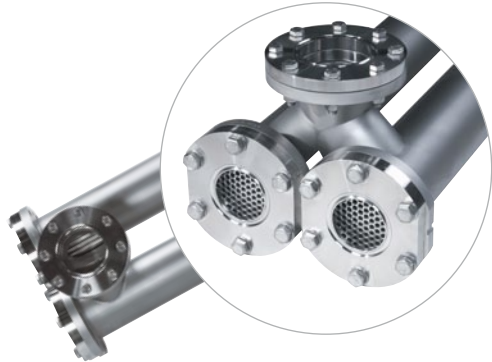

VARITUBE® HS

Function principle

Flow devices installed on the bottom plate provide additional, jet-type acceleration of the product in the reducer at the connection bend.

The flow breaks at the outside of the displacement device and generates a transverse flow directly in front of the tube bottom plate.

The transverse flow enables that no fibres collect on the tube bottom plate. Much longer production cycles are thus achieved and furthermore the efficiency will be increased.

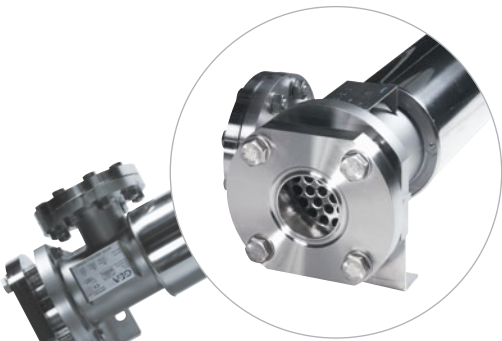

VARITUBE® E

VARITUBE® HS – Multitube with indirect heat exchange, suitable mainly for hot water generation and heating of CIP media for high thermal performance and volume flow rates of up to 60 m³/h. This tubular heat exchanger features product guiding in several inner tubes which are bent around 180°.

The heat-carrying medium flows in the surrounding shell. This design allows for compensation of the different thermal expansions between inner bundle and shell, which could be caused by high temperature differences.

VARITUBE® E – Multitube with indirect heat exchange, suitable mainly for hot water generation and heating of CIP media for medium thermal outputs and volume flow rates of up to 165 m³/h.

The tubular heat exchanger guides the product through several straight inner pipes surrounded by a carrier medium in a shell. The inner tube is mounted in a floating manner to compensate for the different thermal expansions caused by high temperature differences between shell and inner tube.

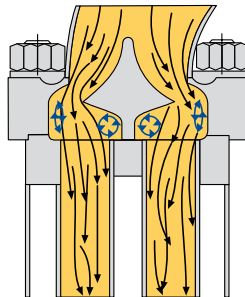

Plate Heat Exchangers

Our heat exchangers are at the heart of all process plants. Based on more than 70 years of experience, our heat exchangers meet the highest demands with regard to performance and hygiene.

Their extremely compact design enables the plate heat exchangers to fulfil demanding thermal tasks on a relatively small floor space. The modular design of the system allows easy capacity increase or reduction. Easy access for maintenance and inspection is also guaranteed. In our systems we use glue-free LOC-IN seals, a decisive advantage for fast seal replacement and shortest downtimes.

VARITHERM® – FREEFLOW – FREEFLOW N

These three different plate types enable us to meet the specific requirements of the process application. Multiple plate sizes and embossed profiles provide an ideal combination of efficient heat transfer and gentle treatment of different types of products with different viscosities.

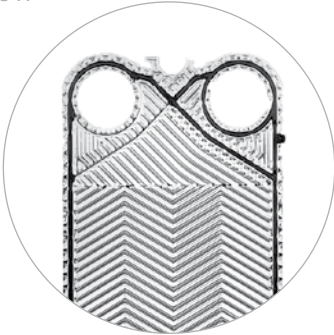

Plate Heat Exchangers

Type VARITHERM®

VARITHERM® plates are used for the thermal treatment of products with low and high viscosities.

Type H



Type V

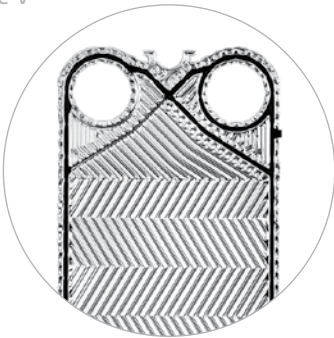

Type M/P

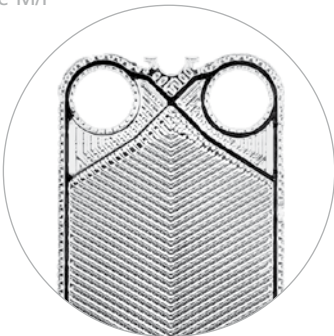

Type Freeflow



You can choose between three types of heat exchanger plates with different embossed profiles:

- Plate type H with horizontal chevron pattern for high thermal efficiency.
- Plate type V with vertical chevron pattern for lower pressure drops.
- Plates type M and P with V-shaped chevron pattern for highest differential pressure resistance.

Type NT – High performance plates with optimized wave flow pattern (OptiWave). A wide range of possible sizes and shapes result into a perfect, tailor made design to fulfill exact operating requirements.

Type NT



Type Freeflow N

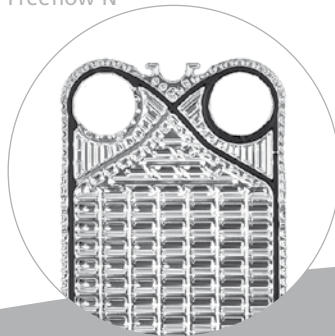

Type FREEFLOW – The FREEFLOW plates are press-formed heat transfer plates in cup-type design without support points in the flow channels (widths of up to 12 mm). Even fruit juices containing fibres with a length of 10 mm and a solid content of up to 10 % can be processed without problems.

Type FREEFLOW N – A plate with horizontal washboard profile. Vertical caterpillar-shaped reinforcing fins channel the product flow and are continued at the top and bottom as flow distributors directed towards the inlet or outlet. For products containing pieces with a diameter of up to 4 mm and operating pressures of up to 10 bar, the Freeflow N plate is the right choice.

Further characteristics of GEA TDS plate heat exchangers

- Efficient heat transfer, i.e. small heat exchange area and thus allowing for low investment costs
- High degree of heat recovery resulting in low energy costs
- Low space requirements due to a compact assembly



Typical Applications for Tubular and Plate Heat Exchangers

Dairy industry	Juice industry	Food industry	Brewery and beverage industry
<ul style="list-style-type: none"> ■ Pasteurising of milk and cream ■ Ultra-high heat treatment ■ Cooling of milk and cream ■ Thermal treatment of yoghurt ■ Cooling of yoghurt ■ Heating of vat milk ■ Thermal treatment of quark milk ■ Cooling of quark ■ Heating and cooling of whey ■ Thermal treatment of cream prior to churning 	<p>Cooling and heating of:</p> <ul style="list-style-type: none"> ■ Fruit and vegetable mash ■ Fruit and vegetable purees ■ Juice containing fibres ■ Juice containing fruit cells ■ Juice containing pulps ■ Concentrates ■ Flavours 	<ul style="list-style-type: none"> ■ Pasteurising of egg and egg products ■ Pasteurising of ketchup ■ Cooling of egg and egg products ■ Cooling of mustard ■ Heating and cooling of sauces ■ Heating and cooling of fats and oils ■ Heating and cooling of mash ■ Heating and cooling of desserts ■ Thermal treatment of pumpable foodstuffs 	<ul style="list-style-type: none"> ■ Wort cooling ■ Wort heating ■ Flash pasteurisation of beer ■ External wort boiling ■ Vapour cooling ■ Green beer cooling ■ Beer chilling ■ Yeast cooling ■ Flash pasteurisation of yeast ■ Pasteurisation of carbonated beverages ■ Pasteurisation of mineral water ■ Heating and cooling of wine

Efficiency and Quality

We welcome the challenge given by our customers for economic, efficient, and profitable production plants.

In response, GEA TDS delivers production lines with a competitive advantage to meet the customer's demand for product quality.

Our heat exchangers meet the strict requirements of the Pressure Equipment Directive 97/23/EC. Among other things our plate heat exchangers comply with the bacteriologically demanding US 3A standard.

GEA TDS tubular heat exchangers are also EHEDG approved and certified.

Service

GEA TDS Heat Exchanger Systems stand out in their durability and easy maintenance.

Whatever the concern – be it a matter of inspection or of capacity adjustment – our service organisation is always ready to take care of your heat exchangers through our extensive network worldwide.





Innovative Engineering –
Quality in Line.

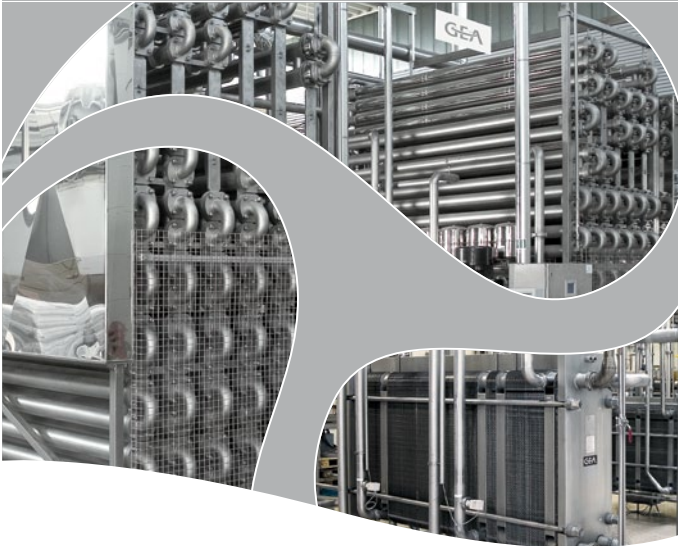

To find out more about GEA TDS process
technology, see www.gea-tds.com.



GEA Process Engineering

GEA TDS GmbH

Voss-Straße 11/13 · 31157 Sarstedt · Germany
Phone +49 5066 990-0 · Fax +49 5066 990-163

Am Industriepark 2–10 · 21514 Büchen · Germany
Phone +49 4155 49-2200 · Fax +49 4155 49-2724

Kruppstraße 3 · 48683 Ahaus · Germany
Phone +49 2561 8602-0 · Fax +49 2561 8602-130

www.gea-tds.com
geatds@geagroup.com